

Carina Island Bath

Product Code: CA1525W / CA1675W / CA1750W

 MADE IN AUSTRALIA



The Carina's planes have been angled to maximize bath space, reclining comfort & function. Its island style allows it to be set away from adjoining walls allowing the viewer to truly appreciate its simple elegance.

- AS/NZ Standard 2023/1995
- Steel rod reinforced rim
- Double reinforced bath base
- Suitable for dual bathing



PRODUCT SPECIFICATIONS

Colour:	High Gloss White
Material:	Premium Sanitary grade acrylic
Length:	1525mm / 1675mm / 1750mm
Width:	765mm / 765mm / 805mm
Height:	440mm / 440mm / 480mm
Capacity:	147L / 166L / 182L [200mm below the bath rim]
Bath Type:	Island
Waste Position:	Centre
Net Weight:	18.5kg / 20.6kg / 25kg
Warranty:	15 years* (refer to decina.com.au)

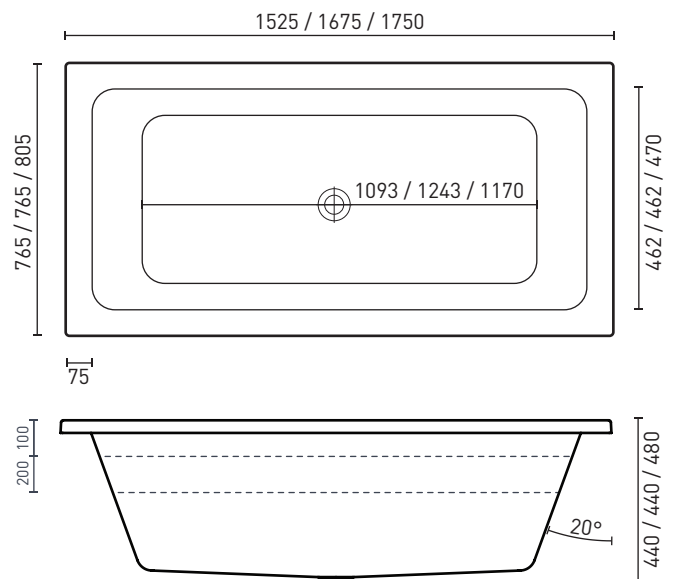

OPTIONAL ACCESSORIES

- 40mm Removable pop-up waste *Chrome* **WA001**
White Gloss **WA002**, *Black Matte* **WA003**
- Pop-up waste & overflow kit *Chrome* **OWA001**
- Pop-down waste & overflow kit *Chrome* **OWA002**
- Pop-down waste & overflow kit *Black* **OWA003**
- Fiore Black Headrest **SY242-A-B**
- EZI Frame / Base Support Frame **Various**

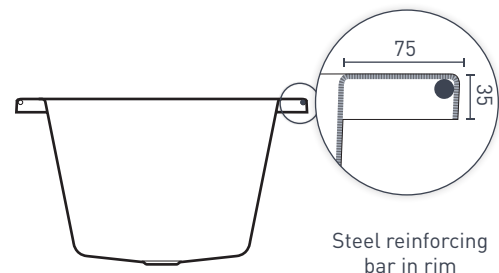

Steel reinforcing bar in rim

DECINA
DISCOVER INDULGENCE

DECINA.COM.AU 1300 DECINA   

*Warranty T&Cs apply, visit decina.com.au Decina reserves the right to change specifications without notice. Due to manufacturing tolerances dimensions may vary +/- 5mm. We recommend installation does not start until after delivery. Please confirm all particulars prior to purchase, call 1300 DECINA or visit decina.com.au